

DESIGNER SERIES
GUTTER SYSTEM
INSTALLATION INSTRUCTIONS

GENERAL DESCRIPTION: The Designer Series Gutter System is a specially designed roof edge drainage product for industrial, commercial, and high end residential type buildings. The system consists of an internal gutter, called the “Liner”, and a decorative cover, called the “Designer Fascia”. The system is attached to the building with an assembly of brackets and your order may also contain other accessories such as mitered corners. As part of this set of instructions there are several drawings which show the component parts and accessories and how they are applied. Please take a moment to review these drawing so you may become familiar with the terms used in this instruction guide.

SKILLS & TOOLS REQUIRED: While the Designer Series gutter system is designed for easy installation it is not designed for installation by those not knowledgeable in the trade such as a home owner. This product requires the experience of a skilled sheet metal mechanic for a proper installation. Basic sheet metal tools required for normal gutter installations are all that is necessary for a proper installation, however, a portable band-saw is better than aviation snips for cutting the decorative fascia sections to size.

DESIGNER GUTTER INSTALLATION INSTRUCTIONS

GENERAL NOTES: Installation of the system begins with the liner sections which make up the actual gutter. The liner is applied in the left to right direction (left to right is read as you stand on the roof and face ground level). This installation instruction assumes that you are starting from an end cap position, see the mitered corner drawing when starting from those conditions. The decorative fascias are installed after the liner installation and can be applied in either direction. Liners require expansion joints at 40' intervals (every 4th piece), the decorative fascias are joined with concealed splice (back-up) plates and require no expansion joints.

Unless so stated on your order, sealants (caulk) and fasteners are not included with your order. We recommend a high grade clear silicone (such as GE) or gutter seal as manufactured by 3M. Use aluminum rivets (with aluminum mandrels) 1/8" x 1/4" for connecting the liners (16 to 21 rivets are required depending on liner size, 15 to 20 at each joint plus one for the decorative fascia splice plate) and 1/8" x 3/8" rivets for connecting the inside straps (4 rivets are required for each liner section). See Rivet schedule (on drawings), for liners made of gauges greater than .040'. Use #10 x 1" stainless screws to fasten the liner's rear edge to wood plates (10 fasteners are required). Review the architectural specifications for the required support bracket fastener(s); since the product is designed to withstand snow & ice loads it is important to use the correct fastener(s) for this bracket. If architectural specifications do not state fastener type use #10 x 2" flat head stainless screws.

DESIGNER GUTTER INSTALLATION INSTRUCTIONS

LINER INSTALLATION: The liner is the internal gutter of the system and it is critical to use good workmanship for this component to function properly. Install the liner as follows;

STEP 1: INSTALLING THE SUPPORT BRACKETS, beginning at the left side of the building's roof edge install enough support brackets to "run or hang" 4 sections of liner (17 brackets). The 1st bracket shall be located 1" from its center to the buildings' end, the 2nd bracket shall be located 27-1/4" "center to center" from the 1st bracket, and the remaining brackets shall be installed at 29-3/4" on center (see drawing #2 & 3). The reason that you do not want to install more than 17 brackets is to be sure that their spacing will align with the notches on the liner (spacing will change later because of expansion joints). If you get them out of alignment it can be time consuming to relocate them. The liner's notch is wider than the support brackets to allow for some variations in locating your support brackets. After you have installed several sections of liner you may become more comfortable with installing more support brackets but we still recommend that you don't get too far ahead of the liner installation. Always start from an end condition! If you must start from a mitered corner, special measurements for the support brackets are required (see drawing #3).

DESIGNER GUTTER INSTALLATION INSTRUCTIONS

STEP 1 CONTINUED: Sloping of gutters is achieved with the proper installation of the support brackets. The best way to allow for slope is by chalking a line on the buildings exterior and fastening the support brackets according to that line. The gutter system will not accommodate a slope greater than 1/8" in 10' (one section), nor more than 1/2" in 40'. Slopes greater than this are not necessary and will distort the decorative fascia. One final note on support bracket installation, the high point bracket should be installed flush with the top of the wood plate (at the roof surface) with the remaining brackets not exceeding 1/4" below this level. This will allow for proper flashing of roof to gutter when using SAF-Perimeter Systems gravel stop or trims. If you elect to install your support brackets at a lower point, be sure to check and see that your corresponding flashing will accommodate this condition.

STEP 2: INSTALLING THE LINER SECTIONS, begins at the building's left side. The 1st piece should be mounted flush with the buildings edge, simply place the liner into the support brackets with care that all the support brackets fall within the notched areas (see drawing #2). The first and last liner at a building's edge requires end caps installed with rivets and sealants.

DESIGNER GUTTER INSTALLATION INSTRUCTIONS

STEP 2 CONTINUED: Fasten the rear upper edge of the liner with stainless screws through the pre-punched slotted holes. The screw should center the hole and screwed to the point that it is snug to the liner surface but does not warp or bind the liner.

DO NOT OVER TIGHTEN THESE SCREWS, the idea is to let the liner float to allow for thermal movement. Prior to installing the next liner, apply sealant to the inside right edge of this liner (see drawing #5).

Insert the next liner with care to align the support brackets as you did with the preceding piece. If the support brackets are misaligned then their spacing is wrong and you need to move them to the correct position. Do not cut the liner to allow for fit. The liner is tapered with its' left hand end having a notched lip and being slightly smaller in size than its' right end. This allows for a 1" telescoping lap joint. Once in position, rivet the joint with 1/8" x 1/4" rivets (see drawing #5). Touch up the rivet heads with sealant and be sure to check the joint for any sealant voids. As an alternate, you can "pre-assemble" four (4) liner joints together and place the assembly into position at one time. Of course you will need additional man power to handle such large sections. Fasten the rear edge of the liner with stainless screws through pre-punched holes in a snug manner as mentioned earlier. At this time, install your downspout outlets.

DESIGNER GUTTER INSTALLATION INSTRUCTIONS

STEP 3: INSTALL EXPANSION JOINTS at the ends of every fourth (4th) liner which will divide the gutter system into 40' segments. The expansion joint consists of a self-adhesive rubber strip to cover a 1/2" gap joint between adjoining sections. At the end of the fourth (4th) liner, your support bracket spacing will change....install the next bracket at 31-1/4" from the center of the last bracket and then install the remaining brackets at 29-3/4" on center (until the next expansion joint is encountered). See drawing #4 to better understand this. The next liner or set of liners will need to be positioned with a 1/2" gap from the previously installed liners. Apply the self-adhesive rubber strip (see drawing #4), being careful to achieve a good bond of rubber to metal. This completes the application of the liner's expansion joint.

It is critical to the performance of the system that expansion joints be installed at 40' intervals. The only exception is; you may omit expansion joints for independent runs of liner which do not exceed 50'. The run must receive end caps on both ends to be considered independent. Gutter liners installed without proper allowance for thermal expansion WILL LEAK at their joints. It is best to install all liners, expansion joints, and other accessories prior to the decorative fascia installation.

DO NOT LEAVE LINERS EXPOSED TO WINTER CONDITIONS, (SNOW & ICE) WITHOUT INSTALLING THE DECORATIVE FASCIA. LINERS ARE SUBJECT TO DAMAGE UNDER SUCH CONDITIONS.

DESIGNER GUTTER INSTALLATION INSTRUCTIONS

STEP 4: INSTALL THE “DESIGNER” DECORATIVE FASCIA starting at the end point where the liner was started (actually, since the fascia is “splice connected” you can start at any point and proceed in any direction). The decorative fascia is initially placed into position by hooking its’ lower edge onto the support brackets’ retaining clip and pulling it to a loose position over the support brackets front outermost edge (see drawing #6). Pulling the fascia into position does require some muscle so be careful as it will bend out of its original configuration. The decorative fascia is made of a light gauge material so as to offer a spring fit and if bent you may press it back into shape. In fact, you have to work with the fascia’s joints as you install the material to insure a smooth monolithic look.

Once you have applied your first piece insert a fascia splice plate 1/2 its width into the decorative fascia end which is to butt the next fascia section. Rivet the splice plate (with two rivets only) to this fascia section. Install the next fascia in the identical manner. Do not rivet the splice plate to both fascia sections....this will cause the product to bind from thermal movement. Install no more than two (2) to three (3) decorative fascias at a time since you will need to check their alignment from ground level after you have installed the inside straps. Do not install fascias that have been cut shorter than 48” in length. Do not apply splice plates as joint covers.

DESIGNER GUTTER INSTALLATION INSTRUCTIONS

STEP 5: INSTALL THE INSIDE STRAPS by threading them through the two rectangular holes located in the liner's outer edge (see drawing #7). As they come to rest in their correct position be sure that they engage the decorative fascia's lip....this is important as this is how the fascia is locked into position. Once the inside strap is in position, rivet it to the liner (DO NOT NAIL) with 1/8" x 3/8" aluminum rivets. As you continue to install straps you need to check the fascias' alignment, especially at the joints. Fascias with curved bends are subject to spread during transit and may need to be worked slightly to achieve a true and straight application. See drawing #8 for miter instructions.

As you install the decorative fascia sections you will need to cut out the bottom flange area to accommodate downspouts at the outlet location. Cut the fascia sections so that the downspout will extend up and to the bottom of the liner and not rest against the decorative fascia.

There will be times that your installation requires that you cut both liner and fascia to size for a proper fit. It is important that a support bracket is always located within 6" from an end cap termination to properly hold the fascia. In this instance, you will need to notch the liner to accommodate this bracket.

Helpful Hint: You will find it easier to install your straps if you "pre-thread" them through the liner's slotted openings and let them lay loose prior to installing the fascia. Once the fascia is in place, simply pick the loose strap up so it engages the fascia and rivet it in place. By pre-threading these straps it prevents you from having to look in the liner, find the holes and feel thread the strap in place.

*****END*****

1. LINER OUTSIDE MITER
2. LINER, 10' SECTIONS
3. LINER INSIDE MITER
4. SUPPORT BRACKET
5. INSIDE STRAP
6. LINER ENDCAP (LEFT HAND SHOWN)
7. FASCIA SPLICE PLATE, 6" SECTION
8. DESIGNER FASCIA, 10' SECTIONS
9. DESIGNER FASCIA OUTSIDE MITER
10. DESIGNER FASCIA INSIDE MITER
11. DESIGNER FASCIA END CAP (LEFT HAND SHOWN)

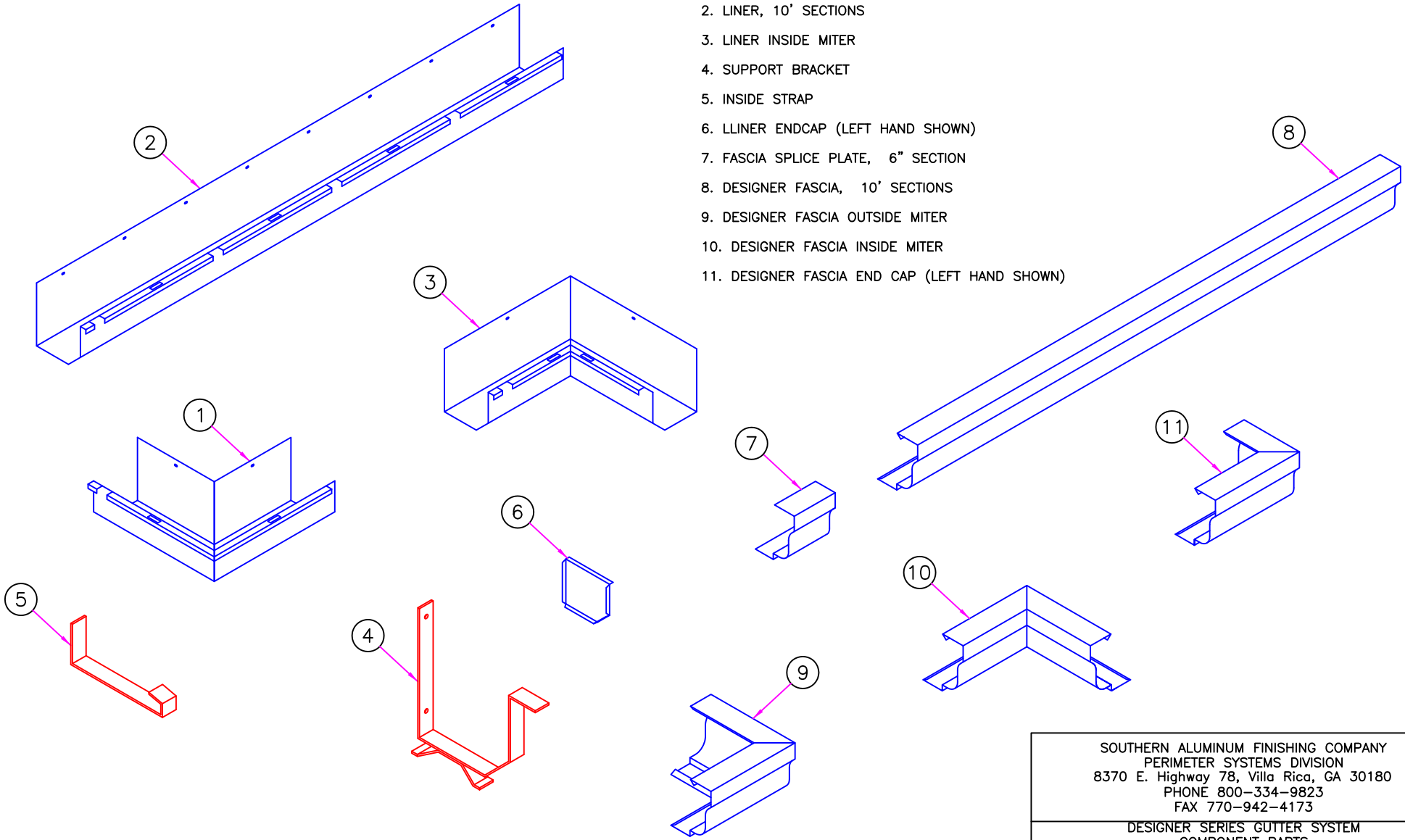

SOUTHERN ALUMINUM FINISHING COMPANY PERIMETER SYSTEMS DIVISION 8370 E. Highway 78, Villa Rica, GA 30180 PHONE 800-334-9823 FAX 770-942-4173		
DESIGNER SERIES GUTTER SYSTEM COMPONENT PARTS (COLONIAL)		
NOT TO SCALE	07-08-15	PAGE 1 OF 9

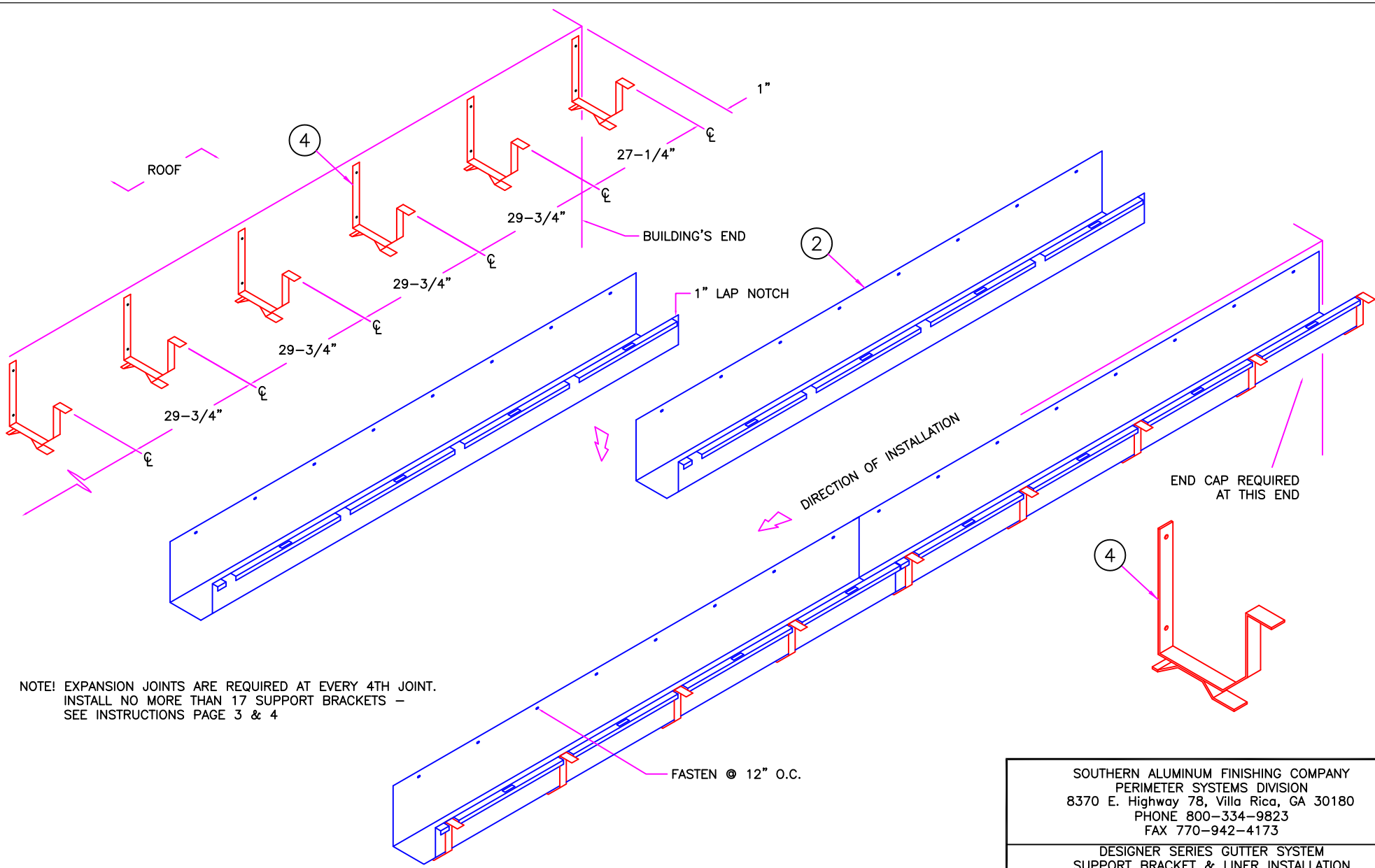

NOTE! EXPANSION JOINTS ARE REQUIRED AT EVERY 4TH JOINT.
 INSTALL NO MORE THAN 17 SUPPORT BRACKETS –
 SEE INSTRUCTIONS PAGE 3 & 4

SOUTHERN ALUMINUM FINISHING COMPANY PERIMETER SYSTEMS DIVISION 8370 E. Highway 78, Villa Rica, GA 30180 PHONE 800-334-9823 FAX 770-942-4173		
DESIGNER SERIES GUTTER SYSTEM SUPPORT BRACKET & LINER INSTALLATION (COLONIAL, CONTEMPORARY & BATTEN)		
NOT TO SCALE	07-08-15	PAGE 2 OF 9

****NOTE A:** LOCATE BRACKET SO THAT A MINIMUM OF 18" OR A MAXIMUM 24" DISTANCE IS HELD. INSTALL AN ADDITIONAL BRACKET IF NECESSARY.

****NOTE:** DO NOT CUT MITERS FOR FIT ... CUT THE LINER. NOTCH LINER AS REQUIRED TO ACCOMMODATE BRACKETS (SEE NOTE A)

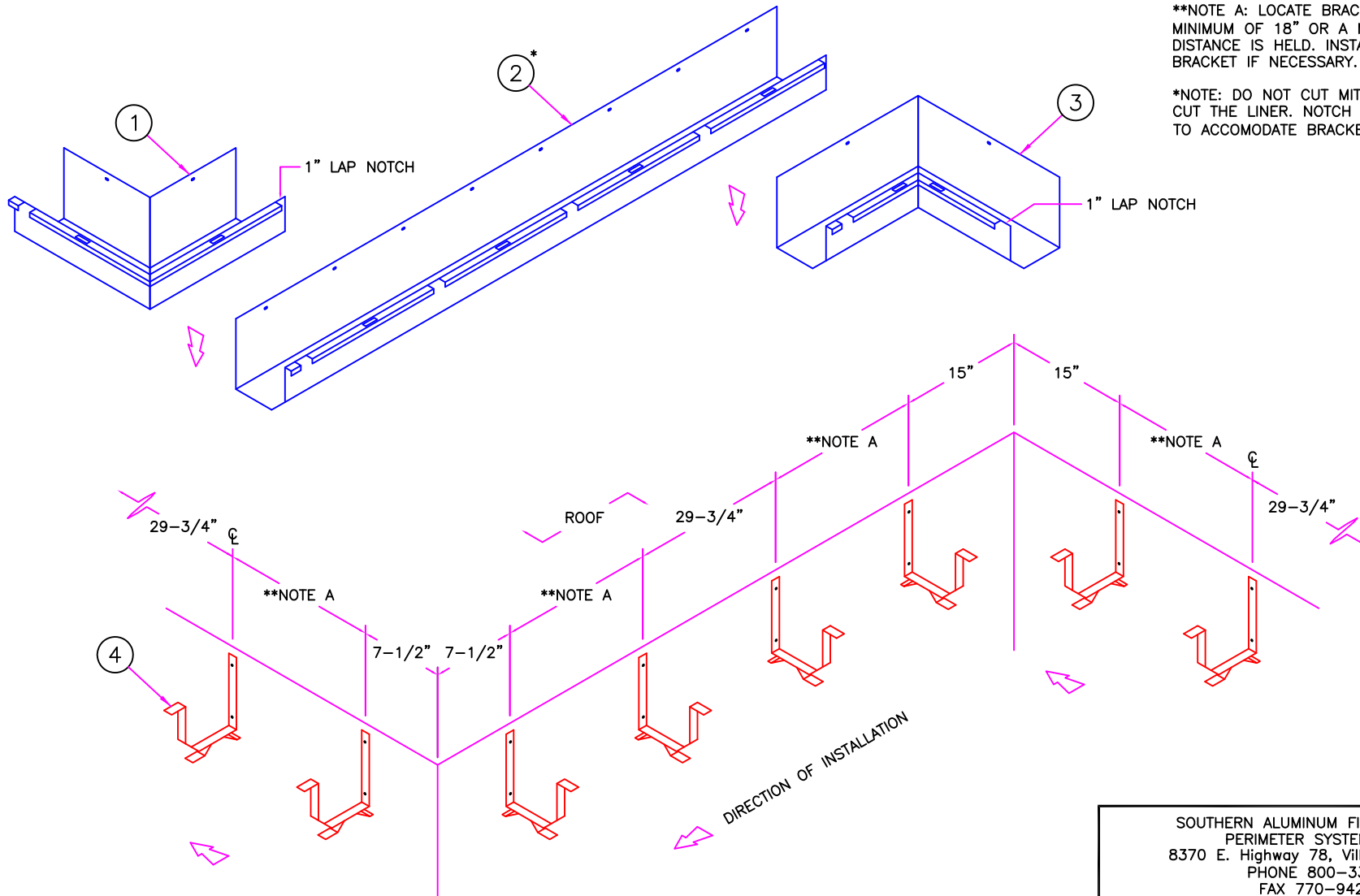

SOUTHERN ALUMINUM FINISHING COMPANY PERIMETER SYSTEMS DIVISION 8370 E. Highway 78, Villa Rica, GA 30180 PHONE 800-334-9823 FAX 770-942-4173		
DESIGNER SERIES GUTTER SYSTEM SUPPORT BRACKET & LINER MITER INSTALLATION (BATTEN & COLONIAL)		
NOT TO SCALE	07-08-15	PAGE 3 OF 9

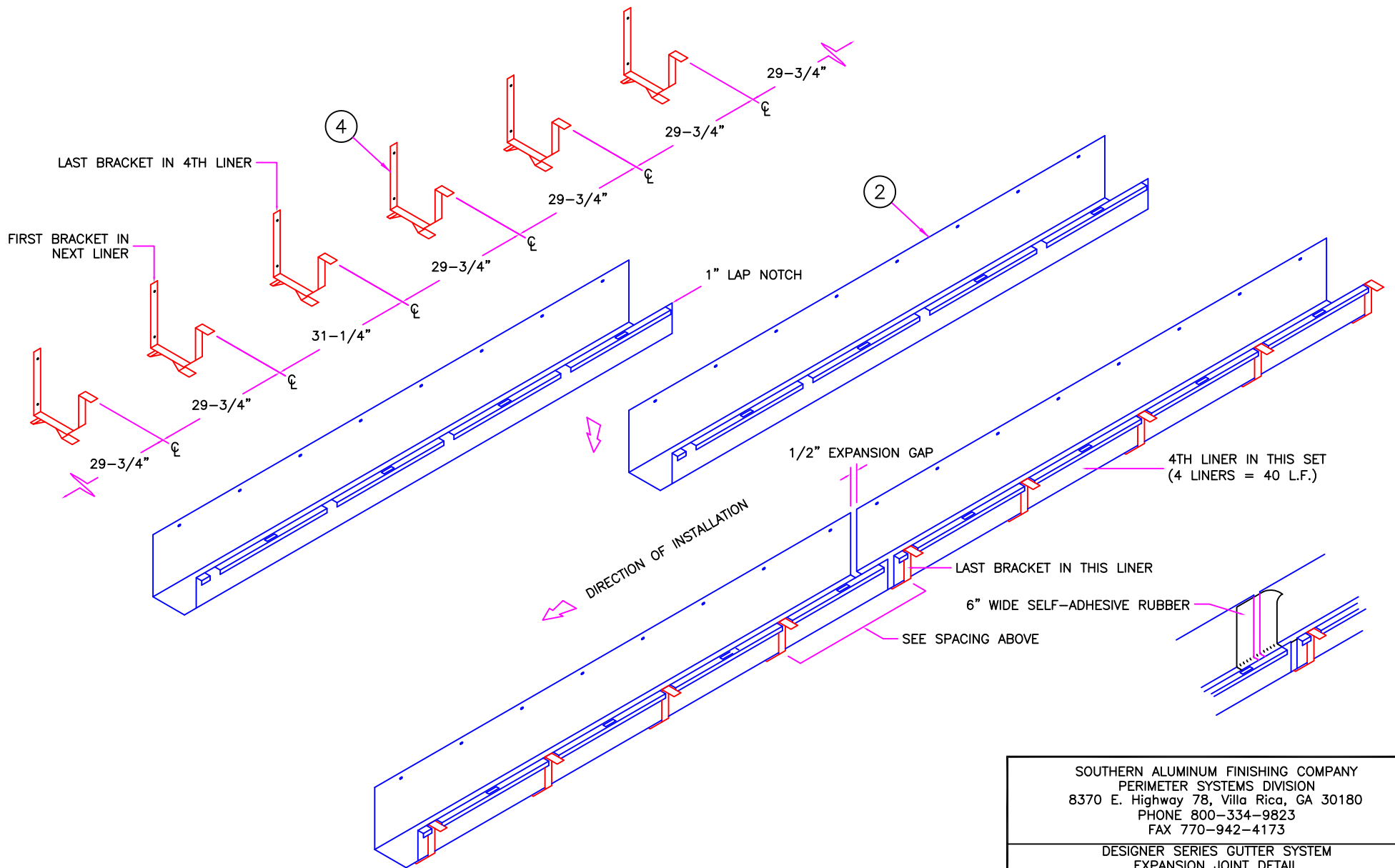

SOUTHERN ALUMINUM FINISHING COMPANY PERIMETER SYSTEMS DIVISION 8370 E. Highway 78, Villa Rica, GA 30180 PHONE 800-334-9823 FAX 770-942-4173		
DESIGNER SERIES GUTTER SYSTEM EXPANSION JOINT DETAIL (BATTEN & COLONIAL)		
NOT TO SCALE	07-08-15	PAGE 4 OF 9

* use 1/4" for 0.040 - 0.060
 use 3/8" for 0.080 - 0.090

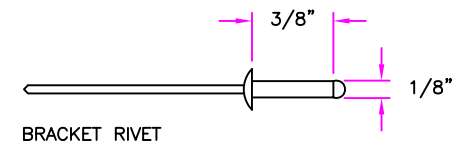
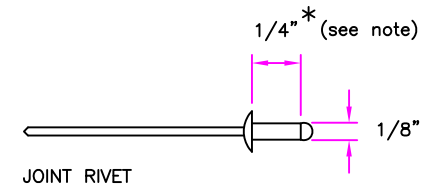
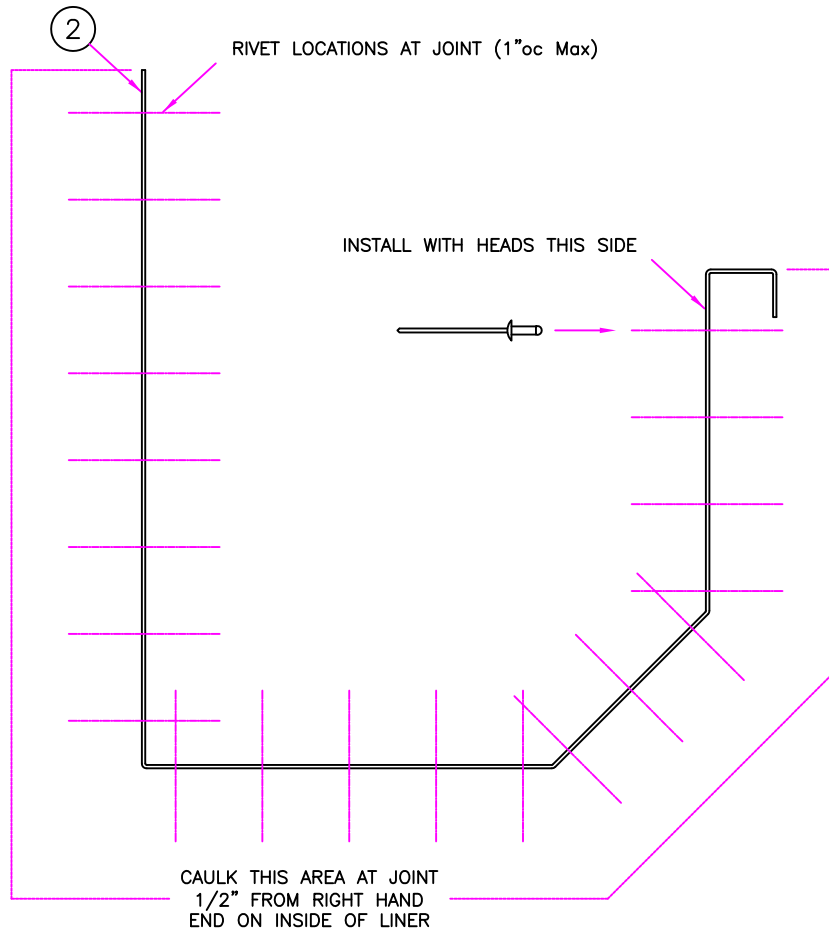

SOUTHERN ALUMINUM FINISHING COMPANY PERIMETER SYSTEMS DIVISION 8370 E. Highway 78, Villa Rica, GA 30180 PHONE 800-334-9823 FAX 770-942-4173		
DESIGNER SERIES GUTTER SYSTEM LINER / JOINT FASTENER DETAIL (COMMON)		
NOT TO SCALE	07-08-15	PAGE 5 OF 9

POSITION THE DECORATIVE FASCIA'S LOWER HEMMED EDGE ON THE SUPPORT BRACKETS' LOWER FLANGE. GENTLY PULL THE FASCIA INTO POSITION OVER THE LINER AND SUPPORT BRACKETS. YOU WILL HAVE TO SPRING THE FASCIA FORWARD AND PULL THE SUPPORT BRACKET INWARD TO BRING THE FASCIA INTO ITS CORRECT POSITION.

ONCE THE FASCIA IS IN POSITION, YOU MAY NEED TO PRESS IT BACK TO ITS ORIGINAL CONFIGURATION ESPECIALLY AT ITS ENDS. NEXT, CHECK THAT IT HAS ENGAGED THE RETAINING CLIP.

INSERT A 4" WIDE SPLICE PLATE INTO THE END OF THE DECORATIVE FASCIA FOR A DISTANCE OF HALF ITS LENGTH (see figure 1). DRILL AND RIVET THE SPLICE PLATE TO THE FASCIA WITH 1 RIVET ONLY. DO NOT RIVET A SPLICE PLATE TO BOTH FASCIA SECTIONS WHICH WILL CAUSE THE PARTS TO BIND.

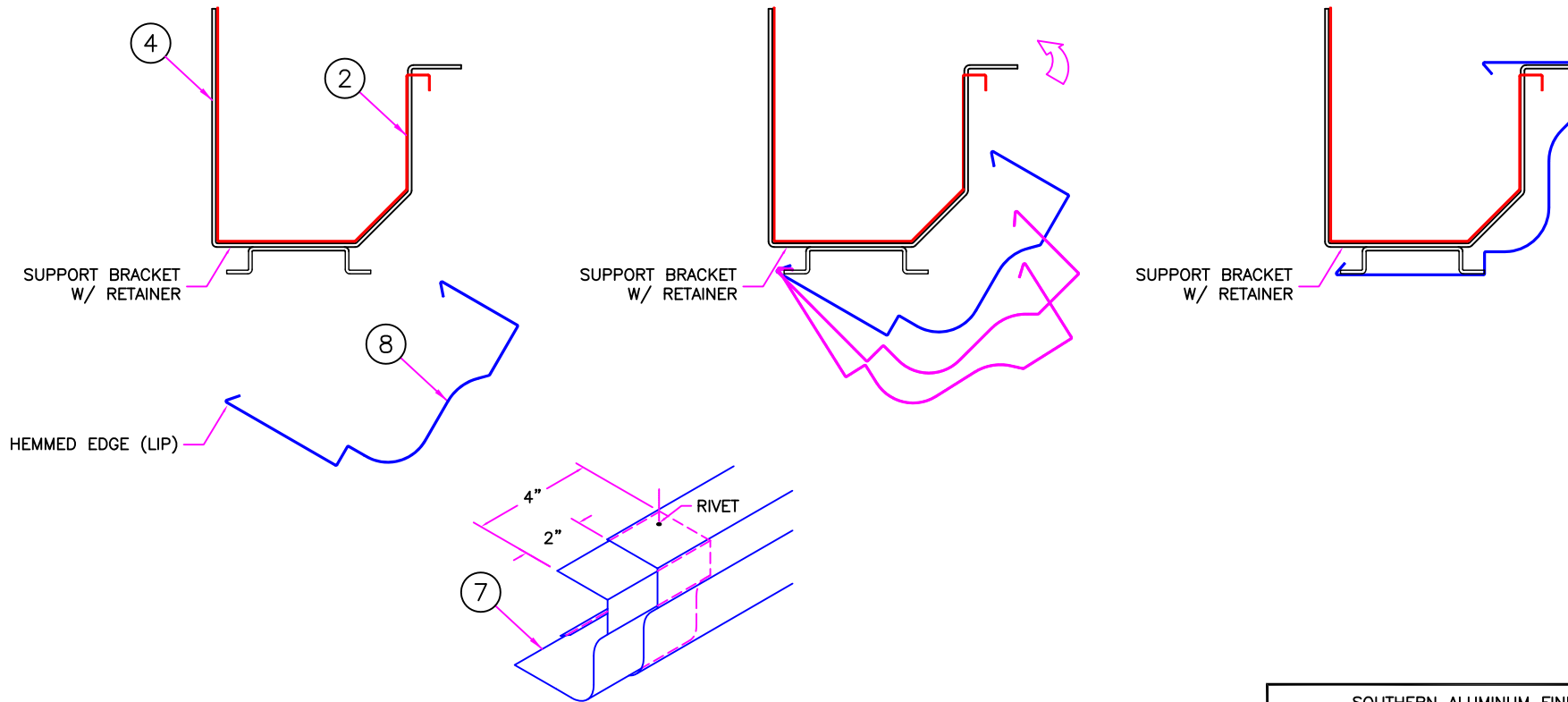

FIGURE #1

**IMPORTANT! ALLOW 3/8" GAP BETWEEN ALL SECTIONS
ONLY ONE BODY IS TO BE RIVETED TO SPLICE FOR STRAIGHT SECTION CONNECTION**

SOUTHERN ALUMINUM FINISHING COMPANY PERIMETER SYSTEMS DIVISION 8370 E. Highway 78, Villa Rica, GA 30180 PHONE 800-334-9823 FAX 770-942-4173		
DESIGNER SERIES GUTTER SYSTEM DECORATIVE FASCIA INSTALLATION (COLONIAL)		
NOT TO SCALE	07-08-15	PAGE 6 OF 9

INSERT INSIDE STRAP (4) INTO RECTANGULAR SLOT ON INSIDE OF LINER. THREAD THROUGH RECTANGULAR SLOT LOCATED IN THE FLAT BEADED PORTION OF THE LINER. YOU WILL HAVE TO PUSH SLIGHTLY OUTWARD ON THE DECORATIVE FASCIA TO GIVE THE STRAP ROOM TO MANEUVER INTO POSITION.

BE SURE THAT THE INSIDE STRAP ENGAGES THE RETURNED LIP AREA OF THE DECORATIVE FASCIA. PULL THE STRAP INTO POSITION, USING VISE GRIPS OR PLIERS LOCK THE STRAP TO THE BACK EDGE OF THE LINER; DRILL AND RIVET IN PLACE WITH 1/8" x 3/8" RIVETS. DO NOT NAIL THIS STRAP THROUGH THE LINER INTO THE WOOD BLOCKING.

AS YOU FASTEN THE INSIDE STRAP INTO POSITION, IT IS IMPORTANT TO CHECK THE LOWER PORTION OF THE DECORATIVE FASCIA TO BE SURE THAT IT HAS REMAINED ENGAGED TO ITS RETAINER BRACKET

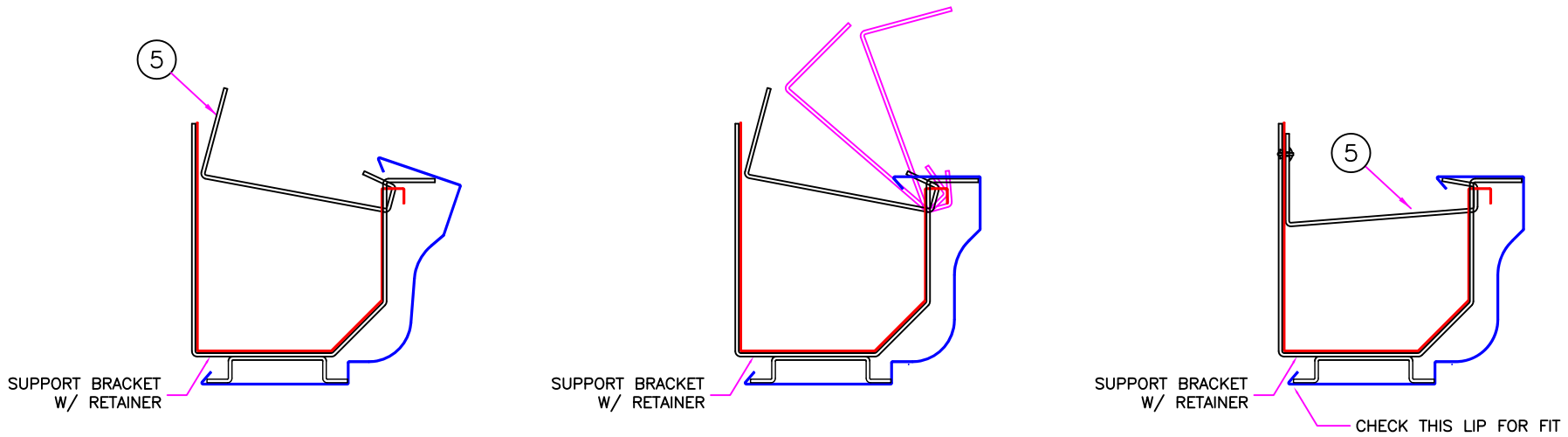

NOTE: AS AN ALTERNATIVE, YOU CAN THREAD SEVERAL INSIDE STRAPS THROUGH THE RECTANGULAR HOLES BEFORE INSTALLING THE DECORATIVE FASCIA. HOOK AND RIVET THE STRAPS AS SHOWN ABOVE.

HELPFUL HINT: YOU WILL FIND IT EASIER TO INSTALL YOUR INSIDE STRAPS IF YOU "PRE-THREAD" THEM THROUGH THE LINER'S SLOTTED OPENINGS AND LET THEM LAY LOOSE PRIOR TO INSTALLING THE FASCIA. ONCE THE FASCIA IS IN PLACE, SIMPLY PICK THE LOOSE STRAP UP SO IT ENGAGES THE FASCIA AND RIVET IN PLACE. BY PRE-THREADING THESE STRAPS IT PREVENTS YOU FROM HAVING TO LOOK IN THE LINER, FIND THE HOLES AND FEEL THREAD THE STRAP IN PLACE.

SOUTHERN ALUMINUM FINISHING COMPANY PERIMETER SYSTEMS DIVISION 8370 E. Highway 78, Villa Rica, GA 30180 PHONE 800-334-9823 FAX 770-942-4173		
DESIGNER SERIES GUTTER SYSTEM INSIDE STRAP DETAIL (COLONIAL)		
NOT TO SCALE	07-08-15	PAGE 7 OF 9

BOTH INSIDE AND OUTSIDE MITERS ARE HELD IN POSITION BY FASTENING THEM TO THE SPLICE PLATES WITH 1/8" x 1/4" RIVETS AS SHOWN. MITERS INSTALLED BEFORE APPLICATION OF THE DECORATIVE FASCIA WILL MAKE YOUR JOB EASIER. THE MITERS ARE NOT DESIGNED TO BE FIELD CUT, CUT YOUR FASCIA FOR PROPER FIELD LENGTH SIZES.

IT IS IMPORTANT THAT THE SPLICE PLATE AND MITER BE FULLY CONNECTED AS THIS IS HOW THE MITER IS HELD IN PLACE. ALLOW A 3/8" GAP JOINT AS WITH THE DECORATIVE FASCIA FOR A UNIFORM LOOK, HOWEVER, YOU DO NOT NEED TO ALLOW FOR EXPANSION. THE MITER IS NOT DESIGNED TO HOOK ONTO A SUPPORT RETAINING BRACKET.

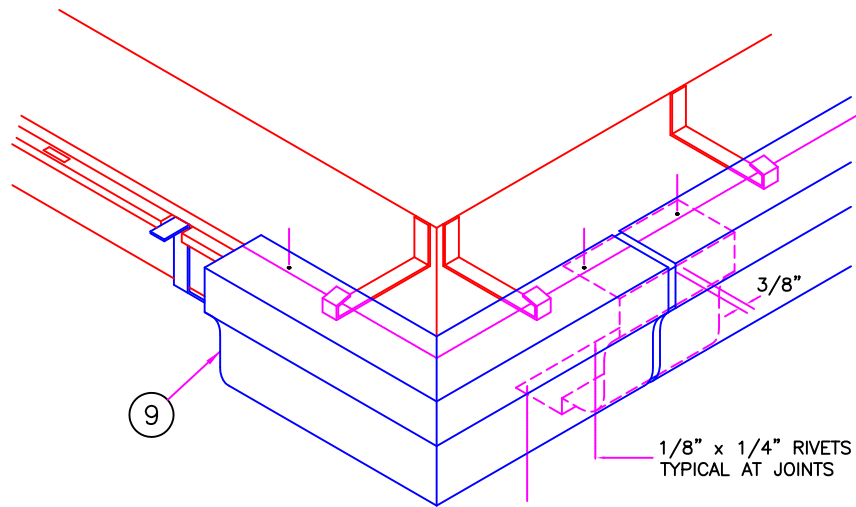

OUTSIDE MITER

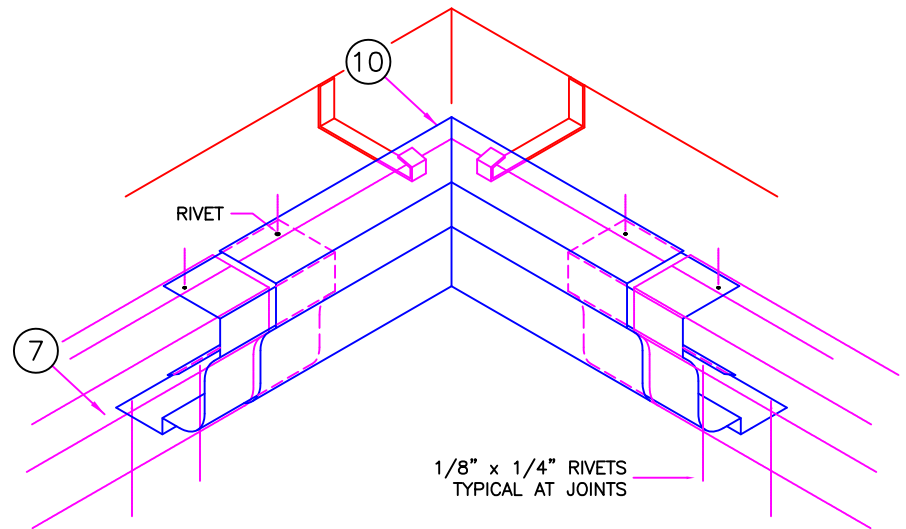

INSIDE MITER

TWO RIVETS AT TOP AND BOTTOM FOR SPLICE CONNECTION IS ONLY AT MITER LOCATIONS.
ONLY ONE BODY IS TO BE RIVETED TO SPLICE FOR STRAIGHT SECTION CONNECTION

SOUTHERN ALUMINUM FINISHING COMPANY PERIMETER SYSTEMS DIVISION 8370 E. Highway 78, Villa Rica, GA 30180 PHONE 800-334-9823 FAX 770-942-4173		
DESIGNER SERIES GUTTER SYSTEM MITER INSTALLATION (COLONIAL)		
NOT TO SCALE	07-08-15	PAGE 8 OF 9

CAST GRATE

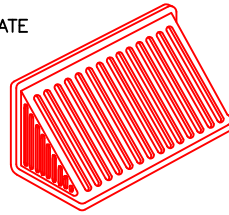

FLASHING CLAMP

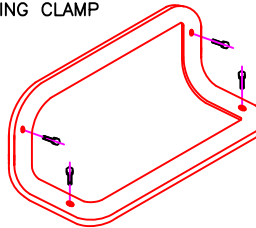

DRAIN

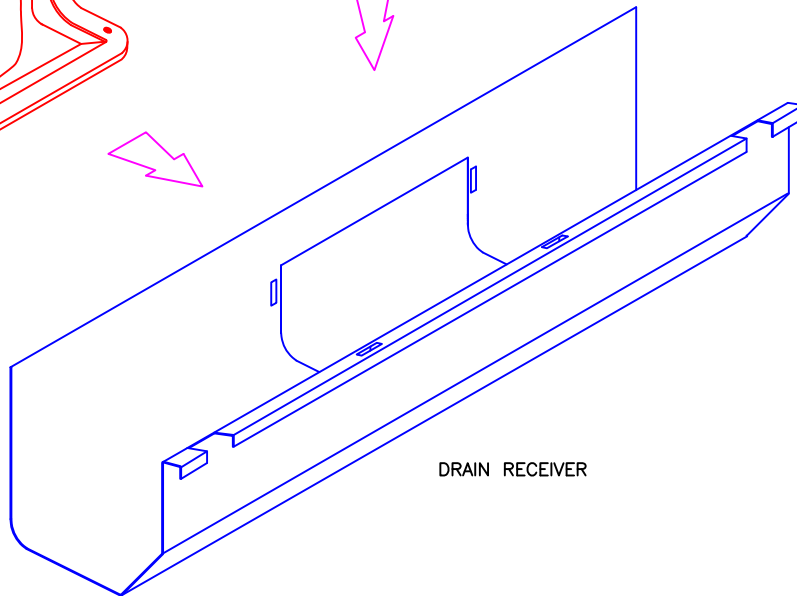
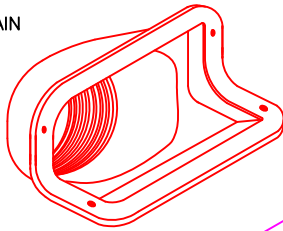

DRAIN RECEIVER

1. DRAINS SHOULD BE MOUNTED TO THE RECEIVER PRIOR TO INSTALLATION. TO MOUNT DRAIN(S), APPLY AMPLE BEAD OF SEALANT TO THE DRAINS FLANGE. SEALANTS ARE NOT FURNISHED, USE A HIGH GRADE OF SILICONE OR EQUIVALENT EXTERIOR GRADE SEALANT.

DRAINS ARE MOUNTED TO THE UNDERSIDE OF THE RECEIVER AND HELD IN PLACE WITH THE FLASHING CLAMP. BOLT FLASHING CLAMP TO THE INTERIOR SIDE OF THE DRAIN RECEIVER THROUGH THE (4) ELONGATED HOLES. BE SURE THAT SEALANT FULLY SEALS THE BOLT HOLE AND BOLT.

GRATE IS PLACED IN POSITION AFTER INSTALLATION.

2. INSTALL LINER WITH ASSOCIATED SUPPORT BRACKETS AND STRAPS AS PER OUR STANDARD INSTALLATION INSTRUCTIONS. CUT MAIN LINER SECTION IF NECESSARY TO PROPERLY ALIGN DRAIN WITH PREDETERMINED DRAIN PIPE LOCATIONS.

SOUTHERN ALUMINUM FINISHING COMPANY
PERIMETER SYSTEMS DIVISION
8370 E. Highway 78, Villa Rica, GA 30180
PHONE 800-334-9823
FAX 770-942-4173

DESIGNER SERIES GUTTER SYSTEM
CONCEALED DRAIN INSTALLATION
(COMMON)

NOT TO SCALE

07-08-15

PAGE 9 OF 9